

Dimensions and Loads

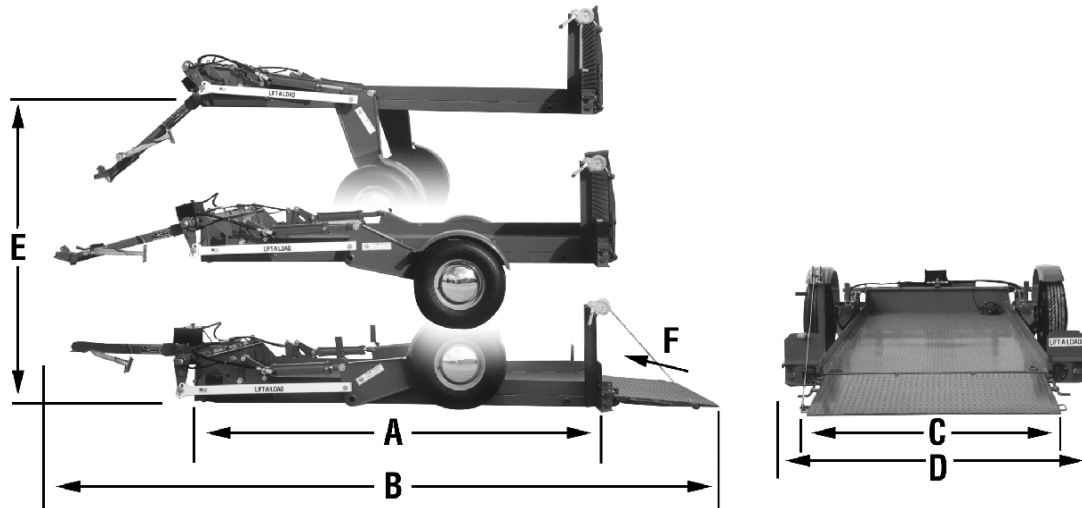

Dimensions:

A = 10' (120")
 B = 20'2" (240")
 C = 5' (59-3/4")
 D = 7'2" (86")
 E = 52" Top of Bed
 F = 6.5 Degree Load Angle

Loads:

4400 lbs Payload
 2309 lbs Trailer Weight
 457 lbs Hitch Empty Weight
 1000 lbs Hitch Fully Loaded Weight
 6709 lbs GVWR
 One (1), 6000 lb Axle

Specifications and Features (Base Trailer)

Ground to Travel to Dock Height	DOT Lights & Reflectors	16 x 6, 8 Bolt Modular Wheels
2 -5/16" Ball Hitch	Grade 55 - 3/16" Diamond Plate Flooring	12" x 2" Electric Brakes
4" Frame Depth	Fold Down Transport Locks	Tie Downs (4)
LT235/85R16E Tire Size	Hydraulic Safety Valves	Rear Platform Support Jacks
36" Tailgate Ramp	Single Pin Grounded +12 VDC Power Cable	Breakaway Kit with Chains
DC Electric / Hydraulic Pump	Blue with White Trim Standard	Tongue Jack

Options

Steel Sides (12") LALP9200	5/8" Tie Down Rail..... LALP9214	Hydraulic Pump Cover LALP3161
40" Fence Pkg..... LALP9205	Spare Tire Carrier..... LALP1147	2-1/2" Pintle Hitch..... LALP3007
Xtra Bed Lgth p/ft LALP9230	Spare Tire w/ Wheel..... 600P6599	Tailgate Winch (Hand)..... LALP9221
Xtra Bed Wdth 6" LALP9235	Cargo Winch 3700# LALP4412	Special Paint Color..... LALP9225
Xtra Tie Downs LALP9211	Aux. Battery Hldr LALP3024	(Machinery Enamel Only)
On-Board Power LALP12396	(Battery not included)	

Items for Tow Vehicle (Installation not Included)

2-5/16" High Rise Ball 600P6203	Brake Controller..... 600P6221
Pump Power Cable..... LALP4351	